

Preliminary

LL-50ABM2E-002

DATA SHEET



QC:王芳

ENG:王新飛

Prepared By:熊盼

Part No.	LL-50ABM2E-002	Spec No.	S/N-10052005	Page	1 of 4
----------	----------------	----------	--------------	------	--------

Features:

- ◆ High intensity
- ◆ Standard T-1 3/4 diameter package
- ◆ General purpose leads
- ◆ Pb-free

Package Dimensions:

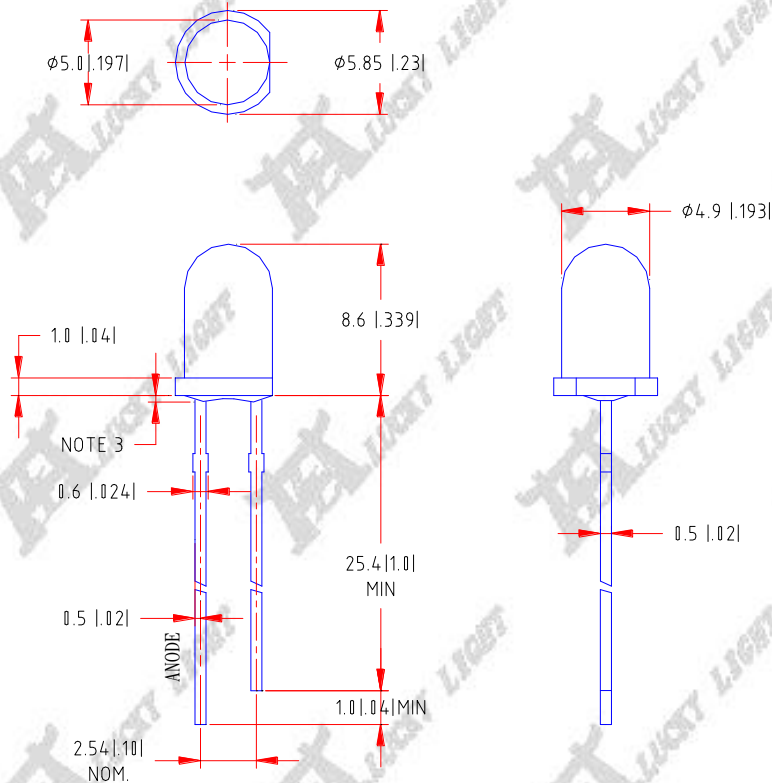

Part NO.	Chip Material	Lens Color	Source Color
LL-50ABM2E-002	InGaN	White Diffused	Super Bright Blue

Notes:

1. All dimensions are in millimeters (inches).
2. Tolerance is $\pm 0.25\text{mm}$ (.010") unless otherwise noted.
3. Protruded resin under flange is 1.0mm (.04") max.
4. Lead spacing is measured where the leads emerge from the package.
5. Specifications are subject to change without notice.
6. Precautions for ESD:
Static electricity and surge can damages the LED. It is recommended to use a wrist band or anti-electrostatic glove when handling the LED. All devices, equipment and machinery must be properly grounded.
7. This data-sheet only valid for six months.



Absolute Maximum Ratings at Ta=25°C

Parameter	MAX.	Unit
Power Dissipation	80	mW
Peak Forward Current (1/10 Duty Cycle, 0.1ms Pulse Width)	100	mA
Continuous Forward Current	20	mA
Derating Linear From 50°C	0.4	mA/°C
Reverse Voltage	5	V
Operating Temperature Range	-30°C to +80°C	
Storage Temperature Range	-40°C to +100°C	
Lead Soldering Temperature [4mm(.157") From Body]	280°C for 5 Seconds	

Electrical Optical Characteristics at Ta=25°C

Parameter	Symbol	Min.	Typ.	Max.	Unit	Test Condition
Luminous Intensity	I_v	460	1100		mcd	$I_F=20mA$ (Note 1)
Viewing Angle	$2\theta_{1/2}$	35	40	45	Deg	(Note 2)
Peak Emission Wavelength	λ_p	463	468	473	nm	$I_F=20mA$
Dominant Wavelength	λ_d	460	470	480	nm	$I_F=20mA$ (Note 3)
Spectral Line Half-Width	$\Delta\lambda$	20	25	30	nm	$I_F=20mA$
Forward Voltage	V_F	2.8	3.5	4.0	V	$I_F=20mA$
Reverse Current	I_R			10	μA	$V_R=5V$

Notes:

- Luminous intensity is measured with a light sensor and filter combination that approximates the CIE eye-response curve.
- $\theta_{1/2}$ is the off-axis angle at which the luminous intensity is half the axial luminous intensity.
- The dominant wavelength (λ_d) is derived from the CIE chromaticity diagram and represents the single wavelength which defines the color of the device.
- Forward voltage measurement allowance is $\pm 0.1V$
- Luminous Intensity Measurement Allowance is $\pm 10\%$



Typical Electrical / Optical Characteristics Curves
 (25°C Ambient Temperature Unless Otherwise Noted)

Spectral Radiance (Peak @ 468nm)

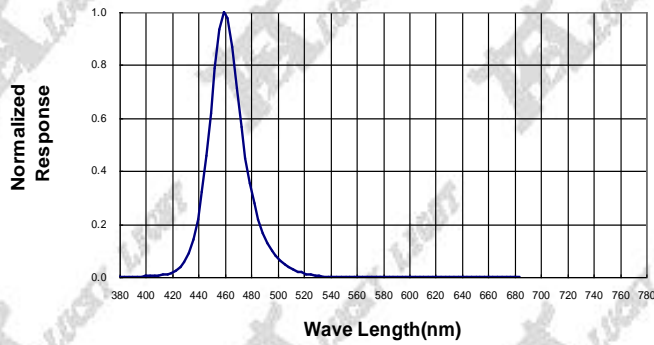

Forward Current vs Forward Voltage

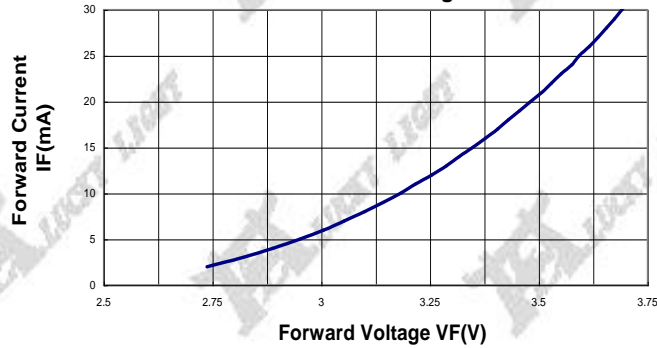

Relative Luminous Intensity vs Forward Current

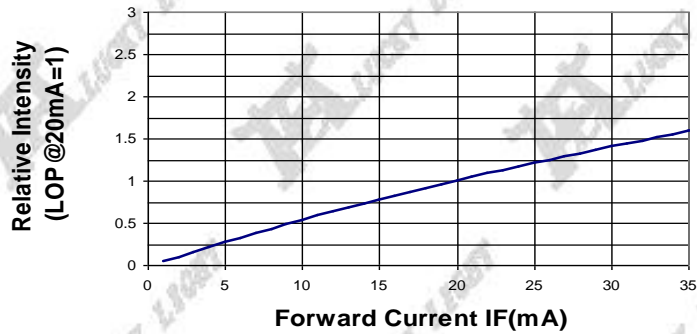

Beam Pattern

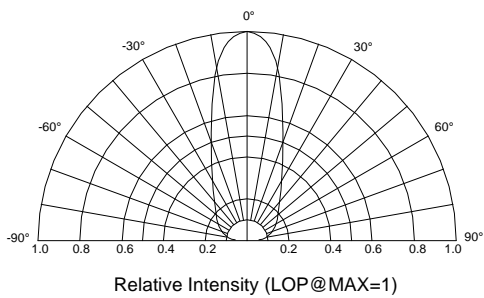

Forward Current Derating Curve

